

R.I.S.®
INTEGRATED SAFETY
DETECTOR



comem®

**R.I.S.® INTEGRATED SAFETY DETECTOR
ACCORDING TO EN 50216-3**



MODEL PATENTED

DESCRIPTION AND FUNCTIONS	MEASURE VALUE	CHECKING TEST
<p>OIL LEVEL (Float) The device indicates any gas evolution or oil level variation. -Slight oil level variation or any insignificant gas evolution is denoted by the float position between "MIN" & "MAX" on the display. -At major oil variation level or gas evolution the float stops at "MIN" and opens/closes the alarm circuit. -Any accumulated gas can be drawn off by the cock provided.</p>	max 170 cm ³	Locate the magnet close to the float (between MAX and MIN). Drawn it downwards until it reaches "MIN". To reset the float to its correct position draw the magnet upwards and detach.
<p>PRESSURE (Pressure switch) This feature measures the internal pressure of transformer. The normal level is to be set by the user according to the transformer manufacturer's instructions. When pressure exceeds a pre set level the alarm circuit is triggered via a N/O or N/C switch.</p>	100 ÷ 500 mbar	With the internal pressure at least 100 mbar set the adjusting knob of the pressure switch to minimum.
<p>TEMPERATURE:</p> <p>"T2" THERMOSTAT SWITCH (ALARM) The feature measures the internal oil temperature of the transformers. The normal operating value is to be set by the user according to the transformer manufacturers instructions. At a pre set temperature on alarm circuit is triggered via a N/O or N/C switch (T2).</p> <p>"T1" THERMOSTAT SWITCH (STOP) The feature measures the internal oil temperature of the transformers. The normal operating value is to be set by the user according to the transformer manufacturers instructions. At a pre set temperature on stop circuit is triggered via a N/O or N/C switch (T1).</p> <p>THERMOMETER The device measures the internal temperature of the transformer, which shall be visualized outside the device through the protection window. The thermometer is equipped with a zero re-setting pointer.</p>	<p>30 ÷ 120 °C</p> <p>30 ÷ 120 °C</p> <p>30 ÷ 160 °C</p>	<p>Open the rear cover using both hands, do not lever at one side only. The adjustment knob of the alarm switch "T2" should be set to zero.</p> <p>The adjustment knob of the stop switch "T1" should be set to zero.</p> <p>The protection window is to be unscrewed so that the pointer shall be set to zero.</p>

GENERAL FEATURES

DEGREE OF PROTECTION (EN 60529)	IP 66
DEGREE OF SHOCK TIGHTNESS (EN50102)	IK 07
SALT-FOGTIGHT	1000 h
UV-RAY RESISTANCE (UNI-ISO 4892 / UNI-ISO 4582)	500 h
TEMPERATURE RESISTANCE	-40 °C ÷ +120 °C
CABLE CONNECTION (WIRE Ø 13 mm UNTILL Ø 18 mm)	Pg 21
CABLE BOX (EN 50005 / EN 60947-7-1 / IEC 947-7-1)	ACCORDING TO STANDARD
WIRE SECTION TO BE USED ON CLAMP BOX	UP TO 2,5 mm²
MAX. RATED PRESSURE	500 mbar
ELECTRICAL CHARACTERISTICS	INSULATED ENVELOPE <input type="checkbox"/>

CURRENT Circuit type	A.C.						D.C.					
	OHMIC			INDUCTIVE (cos φ > 0,5)			OHMIC			INDUCTIVE (L/R < 40 ms)		
Voltage	220	127	24	220	127	24	220	127	24	220	127	24
Electric rating OIL LEVEL	2A	2A	2A	2A	2A	2A	2A	2A	2A	2A	2A	2A
Electric rating PRESSURE SWITCH	6A	6A	6A	2A	2A	2A	0,6A	0,6A	0,6A	0,6A	0,6A	0,6A
Electric rating THERMOSTAT	16A	16A	16A	4A	4A	4A	0,6A	0,6A	0,6A	0,6A	0,6A	0,6A

WIRING DIAGRAM BY EN 50005 STANDARD

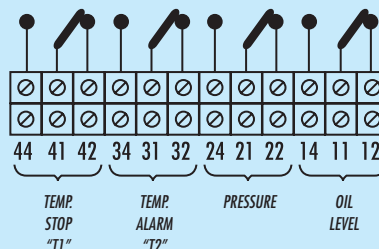

TESTS

R.I.S.[®] has fully passed the type tests prescribed by both European Standard EN 50216-3 and by Comem internal technical standards, which can be listed as follows:

TYPE TESTS:

- Pressure overload: 2.5 bar - 2 minutes - with oil at 115 °C
- Operation at extreme temperatures: at -40 °C and 120 °C
- Classification of the IP 66 protection rating: EN 60529
- Classification of ambient conditions: 4K2, 4Z2, 4B1, 4C2, 4S3, according to EN 60721-3-4
- Mechanical vibrations 4M4 (shock 250 m/sec². Time spectrum "I" : 11 ms), according to EN 60721-3-4
- Classification of seismic conditions Level 2 class 0: according to EN 60068
- Inclined operation: 15°
- Gas or oil volume for contact switching at ambient temperature and at the average working temperature of the transformer: max. 170 cm³
- Contact response time: < 0.5 seconds
- Allowed max. magnetic field value: 25 mT (no intervention of R.S.I.[®]). According to EN 50216-3.
- Mechanical shock protection IK 07: according to EN 50102
- Tightness test - 1000 hours in saline saturated atmosphere. UNI-ISO 9227-93 (NSS).
- Tightness test against UV ageing according to UNI ISO 4892.

ROUTINE TESTS:

Before shipment each piece is also subjected to the following routine tests:

- Tightness test: 30 minutes - 1 bar - with oil at 90 °C
- Operation of thermostats
- Pressure switch operation
- Oil level switch operation.

OPTIONS ON REQUEST

- Pneumatic pump set / oil re-fill in altitude. Code: 5400806001.

SUPPLY CONDITIONS

R.I.S.[®] (product code 1SD4039000) is supplied in a single sturdy carton (dimensions: 400 x 200 x 160 mm, weight: 2.2 kg) and complete with the following accessories:

- Instruction booklet for installation and use.
- Fixing Kit.
- Test report.

R.I.S. MOUNTING INSTRUCTION FITTING ON TO A TRANSFORMER TANK

- $\varnothing 60 \pm 1$ diam. hole on the tank
- Flat gasket (provided with the unit)
- stainless steel fixing brackets (4 pcs packed)
- stainless steel flat washers according to UNI 6592 $\varnothing 8,4$ (4 pcs packed)
- stainless steel spring washers according to UNI 1751 $\varnothing 8,4$ (4 pcs packed)
- stainless steel M8 nuts according to UNI 5588 (4 pcs packed).

Tighten the nuts in position 1,2,3,4 with torque nut $3 \div 4$ Nm crosswise; repeat the operation following the same sequence until the suggested value is reached.

Due to the deformation of the cover during lifting of the transformer, an oil leak could be possible. It is suggested to use covers of suitable thickness (min. 6-8 mm).

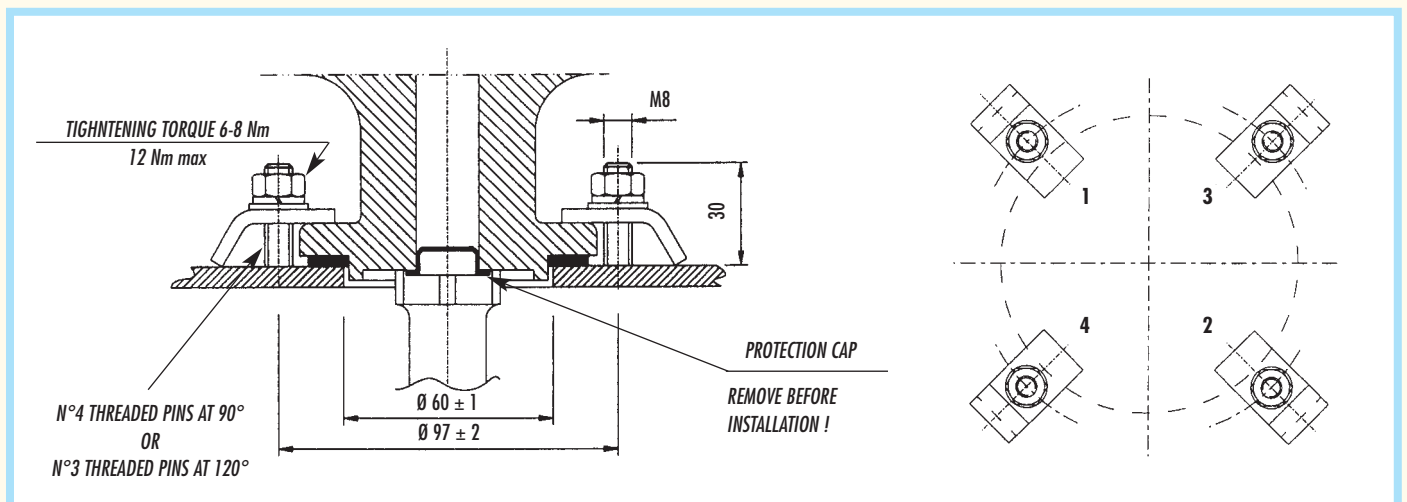



comem[®] - S.p.A

Strada Statale 11, Signolo 22
36054 MONTEBELLO VIC.NO (VI) ITALY
Tel. 0444 449 311 • Fax 0444 449 352 - 440 359
Internet <http://www.comem.com> • e-mail: comem@comem.com

Due to technical improvement of our products, the information contained in this catalogue may be subjected to change without notice.

edizione GB 03/2007 - www.edigraf srl.com